

Chapter 34

ENVIRONMENT

Article I. Junked Vehicles

- Sec. 34-1. Generally.
- Sec. 34-2. Definitions.
- Sec. 34-3. Junked vehicles declared public nuisance.
- Sec. 34-4. Violations; penalty.
- Sec. 34-5. Abatement procedure.
- Sec. 34-6. Notice to abate.
- Sec. 34-7. Abatement hearing.
- Sec. 34-8. Exemptions.
- Sec. 34-9. Disposal.
- Secs. 34-10 - 34-20. Reserved.

Article II. Weed and Rubbish Control

Division 1. Commercial, Business and Industrial Zoning Districts

- Sec. 34-21. Applicability; exceptions.
- Sec. 34-22. Notice of noncompliance.
- Sec. 34-23. Time limit for compliance.
- Sec. 34-24. Filing of complaint in municipal court.
- Sec. 34-25. Emergency abatement.
- Sec. 34-26. Appeals.
- Secs. 34-27 - 34-40. Reserved.

Article III. Outdoor Lighting

- Sec. 34-41. Definitions.
- Sec. 34-42. Lighting requirements.
- Sec. 34-43. Prohibitions.
- Sec. 34-44. Exemptions.
- Sec. 34-45. Effective date and grandfathering of nonconforming luminaries.
- Sec. 34-46. Administration and enforcement.
- Sec. 34-47. Variances.
- Secs. 34-48 - 34-50. Reserved.
- *Historical footnote.

Article IV. Stormwater Detention and Drainage

Sec. 34-51. Purpose.

Sec. 34-52. Scope.

Sec. 34-53. Drainage facilities.

Sec. 34-54. Design standards.

Sec. 34-55. Fee in lieu of detention.

Sec. 34-56. Penalty.

ARTICLE I. JUNKED VEHICLES

Sec. 34-1. Generally.

The procedures for the abatement and removal of a junked vehicle or a part of a junked vehicle as a public nuisance from private property, public property, or public rights-of-way shall be as provided in this article. (Ord. No. 260, 8-26-2004)

Sec. 34-2. Definitions.

The following words, terms and phrases, when used in this article, shall have the meanings ascribed to them in this section, except where the context clearly indicates a different meaning:

Junked vehicle means a vehicle that is self-propelled and:

- (1) Does not have lawfully attached to it:
 - a. An unexpired license plate; or
 - b. A valid motor vehicle inspection certificate; and
- (2) Is:
 - a. Wrecked, dismantled or partially dismantled, or discarded; or
 - b. Inoperable and has remained inoperable for more than:
 1. 72 consecutive hours, if the vehicle is on public property; or
 2. 30 consecutive days, if the vehicle is on private property.

(Ord. No. 260, §1, 8-26-2004)

Sec. 34-3. Junked vehicles declared public nuisance.

A junked vehicle, including a part of a junked vehicle, that is visible at any time of the year from a public place or public right-of-way:

- (1) Is detrimental to the safety and welfare of the public;
- (2) Tends to reduce the value of private property;
- (3) Invites vandalism;
- (4) Creates a fire hazard;
- (5) Is an attractive nuisance creating a hazard to the health and safety of minors;
- (6) Produces urban blight adverse to the maintenance and continuing development of municipalities; and
- (7) Is a public nuisance.

(Ord. No. 260, §2, 8-26-2004)

Sec. 34-4. Violations; penalty.

- (a) A person commits an offense if the person maintains a public nuisance described by section 34-2.
- (b) An offense under this section is a misdemeanor punishable by a fine upon conviction of not less than \$25.00 or more than \$200.00.

- (c) The court shall order abatement and removal of the nuisance upon conviction.
(Ord. No. 260, §3, 8-26-2004)

Sec. 34-5. Abatement procedure.

If the city does not bring a complaint in municipal court it may abate the nuisance as follows:

- (1) The abatement and removal from private or public property or a public right-of-way of a junked vehicle or part of a junked vehicle as a public nuisance shall be as follows:
 - a. Once declared a junked vehicle, the owner or possessor of the junked vehicle is prohibited from reconstructing or making the vehicle operable after removal.
 - b. A public hearing is required before the city council before the removal of the public nuisance.
 - c. Notice identifying the vehicle or part of the vehicle will be given to the state motor vehicle department not later than the fifth day after the date of removal.
- (2) The municipal court for the city may issue necessary orders to enforce the decision of the city council.
- (3) The code enforcement officer of the city shall administer the provisions of this section.
- (4) The code enforcement officer may enter private property to examine a public nuisance, to obtain information to identify the nuisance, and to remove or direct the removal of the nuisance.

(Ord. No. 260, §4, 8-26-2004)

Sec. 34-6. Notice to abate.

- (a) The code enforcement officer of the city shall provide not less than ten days' notice of the nature of the nuisance. The notice must be personally delivered or sent by certified mail with a five-day return requested to:
 - (1) The last known registered owner of the nuisance;
 - (2) Each lienholder of record of the nuisance; and
 - (3) The owner or occupant of:
 - a. The property on which the nuisance is located; or
 - b. If the nuisance is located on a public right-of-way, the property adjacent to the right-of-way.
- (b) The notice must state that:
 - (1) The nuisance must be abated and removed not later than the tenth day after the date on which the notice was personally delivered or mailed; and
 - (2) Any request for a hearing must be made before that ten-day period expires.
- (c) If the post office address of the last known registered owner of the nuisance is unknown, notice may be placed on the nuisance or, if the owner is located, personally delivered.

- (d) If notice is returned undelivered, action to abate the nuisance shall be continued to a date not earlier than the 11th day after the date of the return.

(Ord. No. 260, §5, 8-26-2004)

Sec. 34-7. Abatement hearing.

- (a) The city council shall conduct the hearings under the administrative procedures adopted under this article.
- (b) If a hearing is requested by a person for whom notice is required under section 34-6(a)(3), the hearing shall be held not earlier than the 11th day after the date of the service of notice.
- (c) At the hearing, the junked motor vehicle is presumed, unless demonstrated otherwise by the owner, to be inoperable.
- (d) If the information is available at the location of the nuisance, a resolution or order requiring removal of the nuisance must include the vehicle's:
 - (1) Description;
 - (2) Vehicle identification number; and
 - (3) License plate number.
- (e) The person requesting the hearing has the right to representation of counsel and may cross examine city witnesses but shall be questioned by the council members, regarding the alleged nuisance.

(Ord. No. 260, §6, 8-26-2004)

Sec. 34-8. Exemptions.

- (a) Procedures adopted under section 34-5 may not apply to a vehicle or vehicle part:
 - (1) That is completely enclosed in a building in a lawful manner and is not visible from the street or other public or private property; or
 - (2) That is stored or parked in a lawful manner on private property in connection with the business of a licensed vehicle dealer or junkyard, or that is an antique or special interest vehicle stored by a motor vehicle collector on the collector's property, if the vehicle or part and the outdoor storage area, if any, are:
 - a. Maintained in an orderly manner;
 - b. Not a health hazard; and
 - c. Screened from ordinary public view by appropriate means, including a fence, rapidly growing trees, or shrubbery.
- (b) The following words, terms and phrases, when used in this article, shall have the meanings ascribed to them in this subsection, except where the context clearly indicates a different meaning:

Antique vehicle means a passenger car or truck that is at least 25 years old.

Motor vehicle collector means a person who:

- (1) Owns one or more antique or special interest vehicles; and

- (2) Acquires, collects, or disposes of an antique or special interest vehicle or part of an antique or special interest vehicle for personal use to restore and preserve an antique or special interest vehicle for historic interest.

Special interest vehicle means a motor vehicle of any age that has not been changed from original manufacturer's specifications and, because of its historic interest, is being preserved by a hobbyist.

(Ord. No. 260, §7, 8-26-2004)

Sec. 34-9. Disposal.

- (a) A junked vehicle, including a part of a junked vehicle, may be removed to a scrapyard, a motor vehicle demolisher, or a suitable site operated by the city, another municipality or the county.
- (b) The city, another municipality or the county may operate a disposal site if its governing body determines that commercial disposition of junked vehicles is not available or is inadequate. The city, through agreement with another municipality or the county, may:
 - (1) Finally dispose of a junked vehicle or vehicle part; or
 - (2) Transfer it to another disposal site if the disposal is scrap or salvage only.

(Ord. No. 260, §8, 8-26-2004)

Secs. 34-10 - 34-20. Reserved.

ARTICLE II. WEED AND RUBBISH CONTROL

DIVISION 1. COMMERCIAL, BUSINESS AND INDUSTRIAL ZONING DISTRICTS

Sec. 34-21. Applicability; exceptions.

- (a) *Applicability.* All owners of property zoned B-1, B-2, B-3, B-3 OD, B-4, I-1, QD, and SGD should keep an area of not less than 15 feet adjacent to the paved surface of any roadway, or adjacent property line of residentially zoned property, free and clear of weeds, rubbish, brush and junk. As used herein a weed(s) is defined as uncultivated vegetation growth that has grown to a height of 36 inches.
- (b) *Exceptions.*
 - (1) A tree with a diameter of three inches or more at a height of four feet above ground may remain within the 15 feet of clear area required herein.
 - (2) The 15 feet of clear area adjacent to residentially zoned property shall not be required unless there is a residential unit within 200 feet of any portion of the property line of property zoned B-1, B-2, B-3, B-3 OD, B-4, I-1, QD or SGD.
 - (3) Brush and similar material may be kept within the 15-foot clear area for a period of not more than five days if placed temporarily within the clear area for waste pick-up.

(Ord. No. 267, §1 (app. A, §1), 10-14-2004)

Sec. 34-22. Notice of noncompliance.

- (a) The city shall issue a written notice to a landowner whose property is in violation of the provisions of this division requiring the owner to bring his property into compliance.
- (b) The written notice shall be given by any one of the following methods:
 - (1) By hand delivery to the owner;
 - (2) By certified mail, return receipt requested, to the owner at the owner's address as recorded in the Bexar County appraisal records; and
 - (3) By publication once in a newspaper of local circulation.
- (c) If the notice mailed in accordance with subsection (b) is returned by the U.S. Postal Service marked "refused" or "unclaimed," the validity of the notice is not affected thereby and notice is perfected pursuant to the provisions of this division.

(Ord. No. 267, §1 (app. A, §2), 10-14-2004)

Sec. 34-23. Time limit for compliance.

The notice of violation provided for in section 34-22 shall notify the property owner of the violation and provide the property owner with ten days to bring his property into compliance without penalty. One extension of not more than 15 days may be granted by the city administrator. (Ord. No. 267, §1 (app. A, §3), 10-14-2004)

Sec. 34-24. Filing of complaint in municipal court.

In the event the property owner fails or refuses to bring his property into compliance with the provisions of this division, then, in such event, the city shall file a complaint for violation of this division in the municipal court. (Ord. No. 267, §1 (app. A, §4), 10-14-2004)

Sec. 34-25. Emergency abatement.

In the event that the presence of weeds not less than 48 inches high, rubbish, brush, and junk in the 15 feet clear area creates a situation that presents an immediate danger to the health, life or safety of any person in the opinion of the city's health officer, then, in accordance with this division and V.T.C.A., Local Government Code §217.002, the city may take such actions as are necessary to abate such nuisance. In such event the city shall:

- (1) Cause the work to be done that is necessary to abate the danger;
- (2) Bill the property owner for all necessary expense incurred for performing the work needed plus an administrative fee of \$75.00;
- (3) File a lien against the property on which the work is done, unless payment therefor is made in full to the city within 30 days of such billing to the owner; and
- (4) Provide in the lien for interest at not more than ten percent per annum on any unpaid expenses which the city incurred in abating the nuisance.

(Ord. No. 267, §1 (app. A, §5), 10-14-2004)

Sec. 34-26. Appeals.

- (a) In any event where the city abates a nuisance without prior notice to the property owner, then, in such event, the city shall, within ten days after the city abates the nuisance, give notice to the property owner in the manner required by section 34-22. Included in such notice shall be a description of the violation that created the immediate health danger, a statement of the work that the city did or authorized and an explanation of the property owner's right to request a hearing before the board of adjustment contesting the city's actions within 30 days of the date of the notice. An appeal to the board of adjustment shall stay the payment of all city fees for clearing the property until the board of adjustment considers the appeal.
- (b) The board of adjustment upon payment of the filing fees shall hear the appeal at its next regularly scheduled meeting subsequent to the filing of a notice of appeal to contest the administrative decision of the city official. If the board of adjustment overturns the city's action, the property owner shall not be responsible for any costs.

(Ord. No. 267, §1 (app. A, §6), 10-14-2004)

Secs. 34-27 - 34-40. Reserved.

ARTICLE III. OUTDOOR LIGHTING

Sec. 34-41. Definitions.

Candela means a unit of luminous intensity in any given direction. A candela is commonly called one candlepower.

Changeable electronic variable message sign (CEVMS) shall mean a sign which permits light to be turned on or off intermittently or which is operated in a way whereby light is turned on or off intermittently, including any illuminated sign on which such illumination is not kept stationary or constant in intensity and color at all times when such sign is in use, including an LED (light emitting diode) or digital sign, and which varies in intensity or color. A CEVMS sign does not include a sign located within the right-of-way that functions as a traffic control device and that is described and identified in the Manual on Uniform Traffic Control Devices (MUTCD) approved by the Federal Highway Administrator as the National Standard.

Direct Light means light emitted directly from the lamp, off of the reflector diffuser, or through the refractor or diffuser lens, of a luminary.

Full Cutoff (FCO) means a luminaire light distribution where zero candela intensity occurs at an angle of 90 degrees above nadir, and at all greater angles from nadir. Additionally, the candela per 1,000 lamp lumens does not numerically exceed 100 (ten percent) at a vertical angle of 80 degrees above nadir. This applies to all lateral angles around the luminaire. A full cutoff luminaire is also fully shielded. (See exhibit 1)

Footcandle means a unit of light measurement equal to one lumen per square foot.

Glare means direct light emitted from a luminaire that causes reduced vision or temporary blindness.

Illuminance means the quantity of light arriving at a surface measured in lux or footcandles.

Intermittent Lighting means luminaries that do not remain on for an extended period of time.

Lumen means a unit of luminous flux.

Luminary means a complete lighting unit, consisting of a lamp or lamps and parts designed to distribute light, position and protect lamps, and connect lamps to a power supply.

Nadir means the direction pointing vertically down from the lowest light emitting part of a luminary.

Outdoor Lighting means night-time illumination of an outside area or object by any man-made device.

Sign Code Application Area shall mean the corporate limits of the city and the area of its extraterritorial jurisdiction as defined by Section 42.021 of the Local Government Code.

Temporary Outdoor Lighting means lighting for a specific event of an outside area or object by any man-made device that produces light for a period less than 7 days and with at least 30 days passing before reuse.

Trespass Lighting means light emitted by a luminary that falls outside the boundaries of the property on which the luminary is installed.

(Ord. No. 396, §1, 2-26-2009)

Sec. 34-42. Lighting requirements.

- (a) All commercial outdoor lighting installed within the corporate city limits of the City of Helotes shall be in conformance with the requirements established by this Ordinance.
- (b) Control of Glare.
 - (1) Any luminary that is aimed, directed, or focused in such a manner to create glare perceptible to persons operating motor vehicles on public rights of way or to adjacent residential property owners is prohibited.
 - (2) A luminary used for public roadway illumination shall not exceed 25 feet in height, and the location of the luminary may be positioned up to the property edge so long as no glare is perceptible to adjacent residential property owners.
- (c) Commercial Lighting.
 - (1) Exterior commercial lighting shall comply with the Planning and Zoning Commission's aesthetic design standards.
 - (2) All exterior lighting on commercially zoned real property or property intended to be used as a multifamily residential development shall be full cutoff.
 - (3) *Service stations and other fueling facilities.* Gas station canopies must utilize canopy lights that are fully recessed into the canopy.
 - (4) *Parking Lot Lighting.* All parking lot lighting shall be full cutoff.
 - (5) Outdoor Advertising Signs.
 - a. Lighting fixtures used to illuminate outdoor advertising signs shall conform to the requirements specified in the City's most current sign regulations and shall be full cutoff.
 - b. Outdoor advertising signage of the type constructed of translucent materials and internally illuminated does not require shielding and shall be allowed. Dark backgrounds with light lettering or symbols are preferred.
 - (6) *Municipal Activities.* All municipal activities shall be exempt from the requirements of this Ordinance.

(Ord. No. 396, §1, 2-26-2009)

Sec. 34-43. Prohibitions.

- (a) *Laser Source Lighting.* The use of laser source lighting or any similar high intensity lighting, such as used for outdoor advertising or entertainment, when projected above the horizontal plane is prohibited unless authorized by City Council.
- (b) *Searchlights.* The operation of searchlights for advertising purposes is prohibited, unless authorized by City Council.
- (c) *Changeable Electronic Variable Message Signs.* From and after the effective date, no CEVMS shall be allowed within the Sign Code Application Area.
- (d) *New Off-premise Signs.* From and after the effective date, no new construction permit shall be issued or written permission granted for the erection of an off-premise CEVMS or the conversion of an existing non-CEVMS off-premise sign to a CEVMS, within the Sign Code Application Area.

(Ord. No. 396, §1, 2-26-2009)

Sec. 34-44. Exemptions.

The following are exempt from the provisions of this Ordinance:

- (1) Traffic control signals and devices.
- (2) Temporary emergency lighting (i.e. fire, police, repair workers).
- (3) Moving vehicle lights.
- (4) Navigation lights (i.e. airports, heliports, radio/television towers).
- (5) Seasonal decorations in place no longer than 60 days.
- (6) Sports field outdoor lighting.
- (7) Special situations approved by the City Council for temporary or periodic events.
- (8) Security lights of any wattage that are controlled by a motion-sensor switch and which do not remain on longer than five (5) minutes after activation.

(Ord. No. 396, §1, 2-26-2009)

Sec. 34-45. Effective date and grandfathering of nonconforming luminaries.

- (a) This Ordinance shall take effect immediately upon approval by the City Council and publication, as required by law. This Ordinance shall supersede and replace all previous ordinances pertaining to outdoor lighting.
- (b) All luminaries in place prior to the effective date of the Ordinance shall be grandfathered.

(Ord. No. 396, §1, 2-26-2009)

Sec. 34-46. Administration and enforcement.

- (a) *Enforcement.* This Ordinance shall be enforced by the planning and zoning commission and the City.
- (b) *Penalties.* Anyone charged with negligently, recklessly, knowingly, or intentionally violating any provisions of this Ordinance shall be fined by a penalty of not less than \$25.00 nor more

than \$2,000.00. Each day that such violation continues shall constitute a separate offense and shall be punishable accordingly.

(Ord. No. 396, §1, 2-26-2009)

Sec. 34-47. Variances.

Variances to the terms of this Ordinance may be granted by the City Council where a literal enforcement of the provisions of this Ordinance will result in unnecessary hardship. A variance request must be submitted to the City Administrator setting out the basis for the request along with any associated fees listed in the city fee schedule. No variance can be granted unless:

- (1) such variance will not be contrary to the public interest;
- (2) such variance will be in harmony with the spirit and purposes of this Ordinance;
- (3) the plight of the owner of the property for which the variance is sought is due to unique circumstances existing on the property, and the unique circumstances were not created by the owner of the property and are not merely financial; and
- (4) the variance will not substantially weaken the general purposes of this Ordinance.

(Ord. No. 396, §1, 2-26-2009)

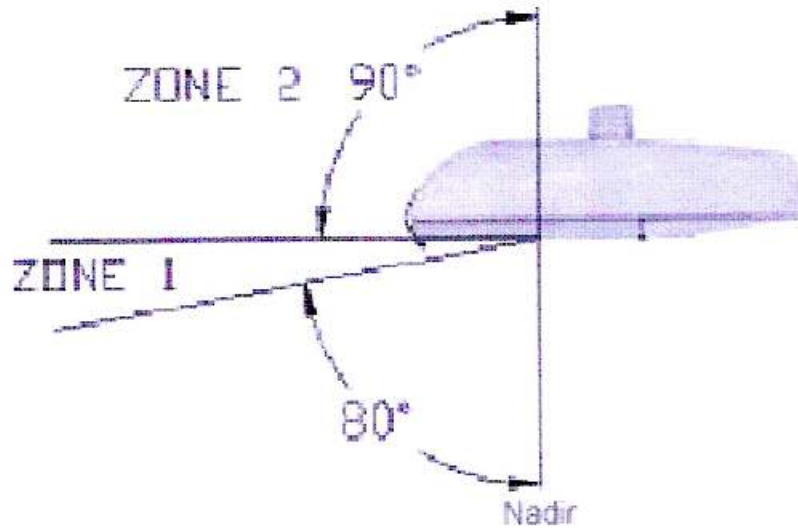

Exhibit. 1

Full Cutoff (FCO) luminaire in Section 34-41. The FCO luminaire on any commercial property (beginning at 80 degrees up from nadir to less than 90 degrees) may emit up to 100 candela per 1000 lamp lumens (10%) at all vertical angles. This applies to all horizontal angles around the luminaire. This information can be provided on the packaging of the outdoor light or from the manufacture.

(Ord. No. 396, §1, 2-26-2009)

Secs. 34-48 - 34-50. Reserved.

Historical Note: Ord. No. 396, §1, adopted February 26, 2009 repealed the former Art. IV. Ord. No. 306, § 2(Exh. A), adopted July 25, 2006, repealed the former Art. IV. The former Art. IV pertained to similar subject matter and derived from Ord. No. 283, Ex. A(1.1, 2.1--2.8, 3.1, 4.1, 5.1), adopted Sept. 22, 2005.

ARTICLE IV. STORMWATER DETENTION AND DRAINAGE

Sec. 34-51. Purpose.

The purpose of this article is to provide adequate measures for the detention and distribution of stormwater in a manner that minimizes the possibility of stormwater flooding or the adverse impact to water quality during and after development.(Ord. No. 196A, § 1, 2-14-2002)

Sec. 34-52. Scope.

- (a) *Applicability.* This article shall apply to any application for the approval of a subdivision plat, a subdivision replat, a master development plan, a building permit, a change in zoning, a zoning variance, or the redevelopment of property within the city's corporate limits or extraterritorial jurisdiction.
- (b) *Exceptions.* Lots individually platted and developed for single family use shall be exempt from the requirements of this article.

(Ord. No. 196A, §2, 2-14-2002)

Sec. 34-53. Drainage facilities.

- (a) *New development.* Peak stormwater run-off rates for all new development shall be less than or equal to the peak run-off rates from the site's pre-development conditions for the five-, 25-, and 100-year design storm events.
- (b) *Redevelopment.* Peak stormwater run-off rates from an area of redevelopment shall be less than or equal to the peak run-off rates produced by existing development conditions for the five-, 25-, and 100-year design storm events.(c) *Stormwater detention.* Stormwater detention shall be required for all new developments or redevelopment of individual parcels of property to mitigate peak flow rates to pre-development or existing development conditions as stated in subsections (a) and (b) above. The maximum allowable out-flow rate from the detention facility must be restricted to the flow rate for the undeveloped or existing development tract for the five-, 25-, and 100-year frequency.
- (c) *Stormwater detention.* Stormwater detention shall be required for all new developments or redevelopment of individual parcels of property to mitigate peak flow rates to pre-development or existing development conditions as stated in subsections (a) and (b) above. The maximum allowable out-flow rate from the detention facility must be restricted to the flow rate for the undeveloped or existing development tract for the five-, 25-, and 100-year frequency.

(Ord. No. 196A, §3, 2-14-2002)

Sec. 34-54. Design standards.

Stormwater run-off may be determined by using the Austin standard method, the rational method, or similar method acceptable to the city engineer. Calculations and plans of the drainage area in pre-development, existing development or ultimate development shall be submitted, for review and approval by the city engineer, as required in section 34-53. The difference in run-off quantities and the flow rates shall be managed by an onsite storm detention system. The detention system shall be designed to release stormwater at a rate not to exceed that of the pre-development or existing development rate. The design of the detention "reservoir" shall preclude any pooling of water or result in additional identifiable adverse flooding within the subdivision or to other properties. The detention system design must be reviewed for acceptability by the city engineer, who then shall make a

recommendation to the city council, and it shall be approved by the city council before any improvements may be made within the proposed subdivision. The detention system must be maintained in a safe and sanitary manner in accordance with its approved design.(Ord. No. 196A, §4, 2-14-2002)

Sec. 34-55. Fee in lieu of detention.

- (a) The City may, at its sole discretion, accept a fee in lieu of detention. All fees collected will be used for regional detention basins or drainage improvements within the City. The fee for said permit shall be as prescribed in the most recent adopted fee schedule passed and approved by the City Council. The fee shall be non-refundable. (Ord. No. 196A, §5, 2-14-2002; Ord. No. 394, §1, 2-12-2009)
- (b) Notwithstanding section (a) above, owners of properties located within the Old Town Helotes Special District and qualifying for a fee in lieu of detention, as recommended by the City Engineer, shall pay the fee for said permit, as prescribed in the most recent adopted fee schedule passed and approved by the City Council, for the area of actual impervious cover proposed to be constructed at the time of permit issuance. (Ord. No. 431, §1, 5-13-2010)

Sec. 34-56. Penalty.

Any person or firm convicted of violating any of the provisions of this article shall be deemed guilty of a misdemeanor, and shall be fined an amount not less than \$25.00 nor more than \$2,000.00. Each day of violation shall constitute a separate offense. Prosecution or conviction under this section shall never be a limitation to other remedies or relief of violation of this article. In addition to any other remedy provided by law, the city and its agents shall have the right to enjoin any violation of this article by injunction issued by a court of competent jurisdiction or other alternatives as authorized by law. (Ord. No. 196A, §6, 2-14-2002)

Chapters 35 - 37. Reserved.

