

**AN ORDINANCE**

**AMENDING CHAPTER 35 OF THE CITY CODE OF SAN ANTONIO, TEXAS, BY ADDING SECTION 35-339.04 “MILITARY LIGHTING OVERLAY DISTRICTS” TO ARTICLE III, DIVISION 4 “OVERLAY DISTRICTS” AND ADDING SECTION 35-498 “VIOLATIONS OF MILITARY LIGHTING OVERLAY DISTRICTS REGULATIONS” TO ARTICLE IV, DIVISION 11 “ENFORCEMENT, VIOLATIONS AND PENALTIES.”**

\* \* \* \* \*

*WHEREAS*, night training is vital to the missions of the various military bases, camps and installations in and around the City of San Antonio; and

*WHEREAS*, the continued viability of the various military bases, camps and installations for such training purposes is critical to the readiness of the United States military, and the vitality of the City of San Antonio’s economy; and

*WHEREAS*, the Zoning Commission held a public hearing on November 18, 2008 at which time parties in interest and citizens were given an opportunity to be heard regarding establishing provisions for a new zoning district named Military Lighting Overlay District; and

*WHEREAS*, the Zoning Commission has made its recommendation to the City Council regarding the Military Lighting Overlay District for the City of San Antonio; and

*WHEREAS*, joint land use studies may be conducted to determine, among other things, the impact of lighting on military installations; and

*WHEREAS*, the need to regulate the installation and use of outdoor lighting is necessary in the City of San Antonio within five (5) miles of the boundaries of military bases, camps and installations; **NOW THEREFORE:**

**BE IT ORDAINED BY THE CITY COUNCIL OF THE CITY OF SAN ANTONIO:**

**SECTION 1.** Chapter 35, Article III, Division 4 of the City Code of San Antonio, Texas, entitled “Overlay Districts,” is hereby amended by adding section 35-339.04 entitled “Military Lighting Overlay Districts” as follows:

**Sec. 35-339.04. Military Lighting Overlay Districts**

**STATEMENT OF PURPOSE**

The purpose of this section is to establish regulations for outdoor lighting impacting military operations within five (5) miles of the perimeter of Camp Bullis/Camp Stanley,Randolph Air Force Base, and Lackland Air Force Base.

Specific purposes of these lighting districts are as follows:

- To reduce glare and potential distractions to night time training exercises occurring within this area.
- To balance the needs of the military, the City of San Antonio, and property owners regarding responsible development including outdoor lighting within this area.

Designation Criteria. To be designated as a military lighting overlay district, an area must be within five (5) miles of the perimeter of Camp Bullis/Camp Stanley,Randolph Air Force Base, or Lackland Air Force Base; provided, however, that if a Joint Land Use Study determines that lighting regulations are required in a smaller area than those required in a designated district, the City may initiate a rezoning to remove properties from a military lighting overlay district. If a Joint Land Use Study determines that different regulations are required or recommended, the City may modify the district regulations accordingly.

**(a) Zoning Process and Classification**

- (1) This section establishes a military lighting overlay district, specifies the general purposes of the military lighting overlay district and the scope of the standards within that district.
- (2) The military lighting overlay district is established as an overlay to the regular base zoning districts.
- (3) The Planning and Development Services Department shall coordinate with other appropriate departments or agencies in order to evaluate land use, traffic and other development related issues in determining the necessity of establishing a military lighting overlay district. All parties in interest and citizens shall have an opportunity to be heard at a public hearing in accordance with Chapter 211 of the Local Government Code.
- (4) The zoning designation for the military lighting overlay district shall consist of a base zone symbol and the military lighting overlay district symbol “MLOD” as a suffix. Military lighting overlay districts shall be numbered sequentially to distinguish among different districts, i.e., “MLOD-1”, “MLOD-2”, etc.

**(b) District Standards.**

- (1) As used in this article, the following terms shall be defined as follows:
- A *Business:* A person, partnership, corporation, or organization engaged in commerce, manufacturing, or a service; profit and non-profit seeking enterprise or concern. The definition is intended to be broadly construed and shall include, but not be limited to, charitable organizations.
  - B *Candela:* The unit of measure indicating the luminous intensity (candlepower) of a light source in a specific direction.
  - C *Digital Sign:* Catho-ray tube (CRT), flat panel liquid-crystal display (LCD), plasma, aerial imaging, projector or other electronic devices that are at the end-point of a digital signage system, presenting the content to include: Dynamic Signs, Electronic Signs, Digital Media Advertising, as well as signs within a Digital Signage Network, In-store TV Network, Captive Audience Network, Narrowcasting Network, Out-of-home Media Network, Digital Media Network, and Advertising Network.
  - D *Direct light:* Light emitted directly from the lamp, off of the reflector diffuser, or through the refractor or diffuser lens of a luminaire.
  - E *Exempted Nonconforming luminaires:* Any existing luminaires which were lawfully in place according to all applicable City Ordinances at the time, but which do not now comply with all applicable regulations as of the effective date of District designation.
  - F *Foot-candle (fc):* A unit of light measurement equal to one lumen per square foot.
  - G *Full cutoff:* Describes a luminaire light distribution where 100 candela per 1,000 lamp lumens (ten percent) may emit at all vertical angles beginning at 80 degrees up from nadir to less than 90 degrees, and 0 (zero) candela per 1,000 lamp lumens (zero percent) is allowed at 90 degrees (horizontal plane) and all angles above. This applies to all horizontal angles around the luminaire. A full cutoff luminaire is also fully shielded. (See Exhibit 2 (two)).
  - H *Fully shielded:* A lighting fixture constructed in such a manner that all light emitted by the fixture, either directly from the lamp or a diffusing element, or indirectly by reflection or refraction from any part of the luminaire, is projected below the horizontal plane as determined by

photometric test or certified by the manufacturer. A fully shielded fixture is not necessarily full cutoff.

I *Gasoline Filling Station*: Shall have the definition as provided in Appendix A of the Unified Development Code.

J *Glare*: A luminance produced by bright sources in the field-of-view superimposed on the image in the eye reducing contrast and hence visibility.

K *“IESNA” (or “IES”)*: An acronym for the Illuminating Engineering Society of North America. The IESNA makes recommendations for outdoor lighting but does not set outdoor lighting community standards which are set through local regulations.

L *Illuminance*: The quantity of light arriving at a surface measured in foot-candles.

M *Intermittent lighting*: Luminaires that do not remain on for more than five minutes.

N *Lumen*: A unit of luminous flux. For purposes of this Ordinance, the lumen-output values shall be the initial lumen output ratings of a lamp. The lumen rating associated with a given lamp is generally indicated on its packaging or may be obtained from the manufacturer.

O *Luminaire*: A complete lighting fixture consisting of a lamp or lamps together with the parts designed to distribute the light, to position and protect the lamps and to connect the lamps to the power supply.

P *Luminous flux*: A quantitative expression of the brilliance of a source of visible light which is electromagnetic energy within the wavelength range of approximately 390 nanometers (nm) to 770 nm. This quantity is measured in terms of the power emitted per unit solid angle from an isotropic radiator, a theoretical point source that radiates equally in all directions in three-dimensional space.

Q *Nadir*: The direction pointing vertically down from the lowest light emitting part of the luminaire (see Exhibit 2 (two) for an example).

R *Nit*: A unit of illuminative brightness equal to one candle per square meter, measured perpendicular to the rays of the source.

S *Outdoor lighting*: Illumination of an outside area or object by any man-made device that is located outdoors and produces light.

T Temporary outdoor lighting: Lighting allowed as specified in an approved temporary permit pursuant to the requirements of subsection 15.I below.

U Trespass lighting: Light emitted by a luminaire that falls outside the boundaries of the property on which the luminaire is sited.

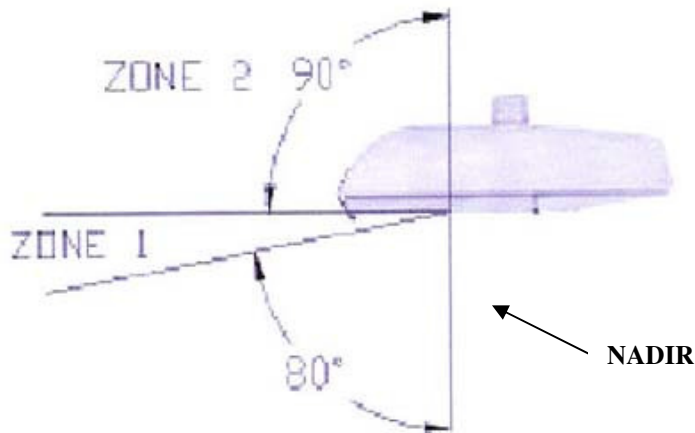

**Exhibit 2**

- (2) All public and private outdoor lighting installed after the effective date(s) of an MLOD district designation shall conform to the requirements established by this section.
- (3) Any luminaire in a new development that is aimed, directed, or focused so as to cause direct light from the luminaire to be directed toward an adjacent military base, camp or installation is prohibited. Such luminaire must be redirected or its light output controlled to eliminate such conditions.
- (4) For new development properties situated at or above one thousand two hundred (1,200) feet in elevation (above sea level), and which are situated within one (1) mile from the perimeter of the affected military installation, all lighting shall be fully screened from the affected military installation(s). Methods of screening can include, but are not limited to, fencing and landscaping.
- (5) **Residential Lighting.**

A No trespass lighting within residential areas may exceed one and one half (1½) foot-candles at the property line, with the exception of intermittent lighting which can be up to two (2) foot-candles.

B All lighting within residential areas must comply with Commercial lighting subsections (6) A - E below.

**(6) Commercial lighting.**

A All lighting fixtures installed on any commercial property and which include or exceed two (2) foot-candles shall be fitted to render them full cutoff (no light output emitted above 90 degrees at any lateral angle around the fixture.) See "Acceptable Fixture" designation as shown in Exhibit 3. The manufacturer or firm handling the installation of outdoor lighting must provide documentation to prove full cutoff status of outdoor lighting to the Planning and Development Services Department during the plan review stage.

**Exhibit 3**

**Acceptable vs. Unacceptable Fixture Examples**

## Unacceptable Fixtures

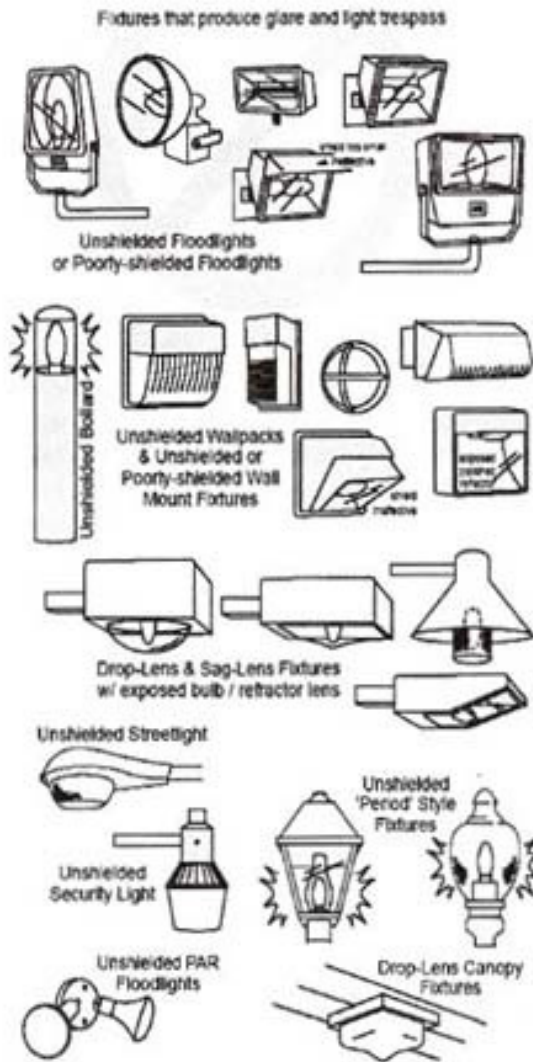

## Acceptable Fixtures



- B. For lighting horizontal tasks such as roadways, sidewalks, entrances and parking areas, fixtures must meet "full cutoff" criteria (no light output emitted above 90 degrees at any lateral angle around the fixture).
- C. Intermittent lighting must be of the "motion sensor" type that stays on for a period of time not to exceed five (5) minutes and has a sensitivity setting that allows the luminaire to be activated only when motion is detected on the site.
- D. All trespass lighting shall not exceed two and one-half (2½) foot-candles measured at the property line, except that residential trespass lighting is regulated in subsection b(5)A above.

- E. Floodlight fixtures must be aimed so as to prevent direct radiation of light into the open sky at any angle above the horizontal plane as shown in Exhibit 4 and verified using a tool such as shown in Exhibit 5.

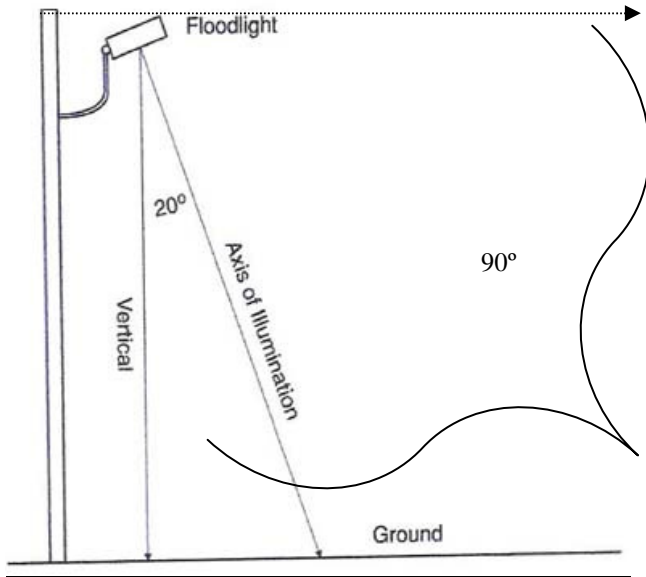

Horizontal plane is parallel to the ground and perpendicular to the vertical line

A floodlight may not be so positioned as to direct illumination at or above the 90° angle of the horizontal plane.

**Exhibit 4**

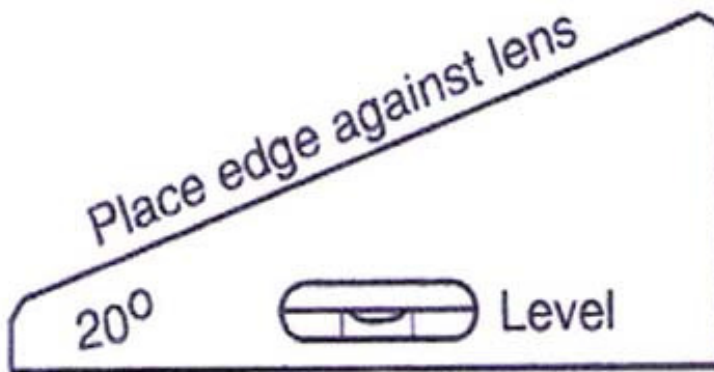

**Exhibit 5: This is a tool for aiming lights such as the floodlight represented in Exhibit 4. This tool would verify the angle of 20° by placing the upper edge of the tool against the floodlight lens and adjusting the floodlight so that a level parallel to the bottom edge shows level.**

- F. With the exception of lighting which is required for security and safety such as parking lot illumination, businesses must turn off outdoor lights emitting illumination levels exceeding 2 foot-candles (fc) after 11:00 p.m.

G. Lighting installed to illuminate construction sites in order to secure or protect equipment at night shall meet the requirements of subsection b.6.A above.

**(7) Gasoline filling stations:**

A Outdoor sales and service station canopies must utilize canopy lights that are fully recessed into the canopy or are fully shielded by the canopy.

B The following average maintained illuminance levels for service stations must not be exceeded:

<u>Service Station Component</u>	<u>Lighting Level</u>
<u>Approach</u>	<u>2.0 fc</u>
<u>Driveway</u>	<u>2.0 fc</u>
<u>Pump Island</u>	<u>10.0 fc</u>
<u>Building Façade</u>	<u>3.0 fc</u>
<u>Service Areas</u>	<u>3.0 fc</u>
<u>Landscape Highlights</u>	<u>2.0 fc</u>

Note: fc = foot-candle

**(8) Parking lot and parking structure lighting:**

A Total pole and fixture height shall comply with Section 35-392.b of this Chapter.

B All lighting luminaires in surface parking lots and on the top decks of parking structures shall be fitted to render them full cutoff.

C Reflectivity. In order to allow for a variety of surface material options:

a. Surface parking lots shall be designed, coated or constructed so that illumination levels are no more than what is reflected from asphalt at an average of twenty (20) foot-candles.

b. Top decks of parking structures shall be designed, coated or constructed so that illumination levels are no more than what is reflected from asphalt at an average of fifteen (15) foot-candles.

D One hour after closing, businesses must turn off at least fifty percent (50%) of lighting luminaires in surface parking lots and on top decks of

parking structures; however, those luminaires turned off may be set to function utilizing a motion detector system or dimmer.

(9) **Outdoor sign lighting.**

- A All signs located within three-quarters (¾) of a mile of Camp Bullis/Camp Stanley shall be positioned in such a manner and contain “dark sky” approved shielding devices as to significantly reduce spillover light affecting the military installation and operations. In no instance shall signs be positioned facing parallel to the adjacent boundaries of the military installation.
- B On-premise signs may remain illuminated during regular business hours, but may not be illuminated later than one-half (½) hour after the business is no longer open to the public, nor prior to the daily opening of the business to the public.
- C On-premise signs utilizing neon tube lighting shall be exempt from the requirements of subsection B above.
- D Single-tenant on-premise signs shall be illuminated at a level no greater than seven (7) footcandles measured at five (5) feet from the light source. Multi-tenant on-premise signs shall be illuminated at a level no greater than twelve (12) footcandles measured at five (5) feet from the light sources.
- E Exterior means of illumination utilized for on-premise signs shall be positioned in a “top down” manner as depicted in Exhibit 4. Bottom-mounted fixtures shall not be used for on-premise signs.
- F Conventional non-digital off-premise signs shall employ an illumination system utilizing no more than two (2) luminaires to illuminate each sign message area (face). Each luminaire shall employ a refractor and hood that focuses the light on to the sign face and each luminaire may not exceed 400 watts.
- G All on-premise and off-premise digital signs shall be illuminated at a level no greater than 0.3 footcandles over ambient light levels for the location and time and shall employ light cutoff devices, such as louvers, to minimize light escaping above the horizontal plane. This subsection (9)(G) is not exempt from the requirements of subsection (9)(B) above.
- H Other than the requirements contained in subsection b(1) and subsection (9), the installation, operation, alteration, repair or improvement of an illumination device used for an off-premise sign are not subject to the

other provisions of sections 35-339.04 or 35-498, but are subject to provisions of Chapter 28 and Chapter 35 as appropriate.

- I Nothing in this section shall be interpreted to authorize signs in areas of the City prohibiting signs.

**(10) Street lighting.**

- A This subsection regulates the illumination levels for street lights that are installed on any street and must follow the American National Standard Practice for Roadway Lighting under the IESNA.
- B Street light illumination must follow the guidelines in paragraph D of this subsection unless a licensed professional engineer, trained and experienced in the science of illumination engineering, deems other illumination levels based on IESNA standards more appropriate for existing conditions and staff concurs with this assessment.
- C All standard streetlights must utilize full cutoff type luminaires that are installed level to the ground in two intersecting perpendicular planes (see Exhibit 6), and should be horizontally level in all directions.

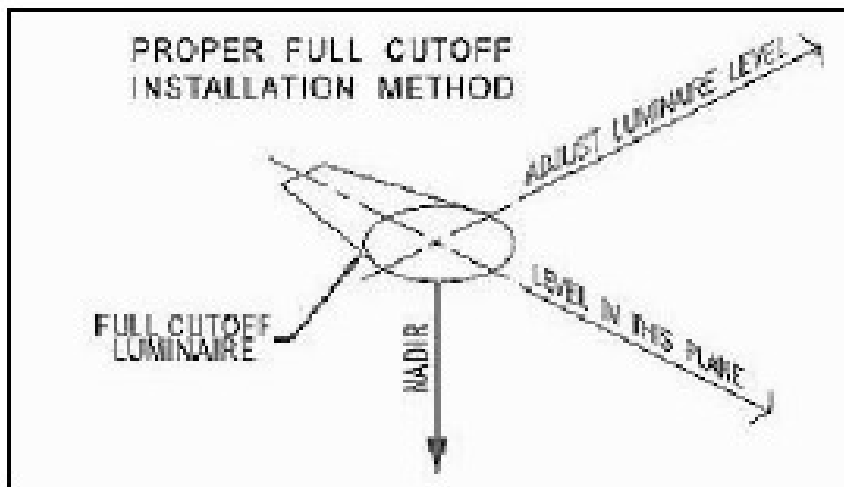

**Exhibit 6 .**

- D New ornamental street lights must be classified as either IES "Full Cutoff" or IES "Cutoff" as determined by a valid photometric report. This report must be generated for the specified model by a qualified testing lab (testing to IES standards) and must include a full vertical evaluation through 180 degrees, otherwise that fixture will be unacceptable.

- (11) **LEED Standards.** It is encouraged that, where possible, LEED (The Leadership in Energy and Environmental Design) certified lighting standards be substituted for the requirements of subsections 5 through 10 above, so long as the minimum standards of this section are met. If a project utilizes LEED certified lighting standards, the remainder of a project's design does not have to meet LEED standards.
- (12) **Tower and Structure Lighting.** See FCC or FAA regulations.
- (13) **Other Prohibited Lighting.** Unless authorized by the City Council by specific Ordinance for a special event:
- A The use of laser source light or any similar high intensity light, such as used for outdoor advertising or entertainment, when projected above the horizontal plane is prohibited; and
- B The operation of searchlights for any purposes is prohibited.
- (14) **Unmanned Automated Teller Machine lighting.** Unmanned automated teller machines (ATMs) shall comply with the requirements as listed in section 59.307, Texas Finance Code and this Article by utilizing fully shielded or full cutoff luminaires as appropriate.
- (15) **Exemptions.** The following outdoor lighting instances are exempt from the lighting requirements of this Ordinance:
- A All legal outdoor lighting in place prior to the effective date of an MLOD district designation. (But see Section 16 below).
- B Outdoor lighting for which light is produced directly by the combustion of fossil fuels.
- C Outdoor lighting used during law enforcement, fire, and medical activities and for meteorological data gathering purposes.
- D Outdoor lighting employed during emergency or night-time repairs of roads and utilities.
- E Lighting required by law to be installed on motor vehicles.
- F Lighting required for the safe operation of aircraft.
- G Outdoor lighting installed on Federal and State facilities; however, voluntary compliance is encouraged.

H Decorative holiday lighting from November 15 through the next January 15.

I Temporary exemptions: Any individual may submit a written request to the Director for temporary lighting and obtain a temporary electrical permit. The permit may grant temporary lighting for a period not to exceed thirty (30) days, with at least thirty (30) days passing before another temporary electrical permit may be issued. The request for temporary lighting must contain the following information in addition to information required to obtain a temporary electrical permit:

- a. Proposed use and location of the outdoor light requested.
- b. Type of lamp(s) to be used, including manufacturer's part number and initial lumens.
- c. Type of light fixture used, including manufacturer's model number and specification (cut) sheets indicating photometric distribution data stated in iso foot-candle diagrams.
- d. Starting and ending dates for temporary lighting use.
- e. Contact information including name of requester, affiliation (if applicable), address and telephone number.
- f. And such other information the Director may require.

**(16) Maintenance and repair of legal nonconforming luminaires.**

A All luminaires lawfully in place prior to the effective date(s) of an MLOD district designation shall have legal nonconforming status.

B Minor repair and maintenance of legal nonconforming luminaires up to 50% of the replacement value is allowed, however any alteration in excess of 50% shall terminate the nonconforming status and at that time all standards of this section must be met.

**(17) Administration.** The Director shall administer this section.

**(18) Variances and Special Exceptions.**

A. The Board of Adjustment may grant a variance to the requirements of this section where a literal enforcement of the provisions will result in unnecessary hardship. A variance request must be submitted to the City

in writing that sets out the basis for the request. No variance can be granted unless it meets the approval criteria outlined in 35-482(e).

- B. A special exception to the requirements of this section may be granted by the Board of Adjustment where a plan's lighting design does not meet strict design standards but alternative methods may be used which meet the intent of the Code.

**SECTION 2.** Chapter 35, Article IV, Division 11 of the City Code of San Antonio, Texas, entitled "Enforcement, Violations and Penalties" is hereby amended by adding section 35-498 entitled "Violations of Military Lighting Overlay District Regulations" as follows:

**Sec. 35-498. Violations of Military Lighting Overlay District Regulations**

- (a) **Violations Defined.** It shall be unlawful for any person, firm or corporation to erect, construct, enlarge, alter, repair, move, improve or convert any illumination device of any type, or cause the same to be done, contrary to or in violation of any provision of this chapter. Any person, firm or corporation shall be deemed guilty of a separate offense for each and every day or portion thereof during which any violation of any provision of this chapter is committed, continued, or permitted.
- (b) **Enforcement.** The Director shall give written notice of noncompliance to the owner/tenant or their agent or other person in control of the property on which an outdoor lighting violation exists. Service shall be made on the owner/tenant or their agent or other person in control of the property:
- (1) In person or by registered or certified mail, return receipt requested; or
  - (2) If personal service cannot be obtained or the address of the owner/tenant or their agent or other person in control of the property is unknown, by posting a copy of the notice on the premises on which the violation exists or by publishing the notice in a newspaper with general circulation in the City.
- (c) **Penalties.** Any person who violates the provisions of this chapter upon conviction shall be guilty of a Class C misdemeanor and shall pay such penalties as the court may decide not to exceed five hundred dollars (\$500.00). Each day's continued violation shall constitute a separate violation. Payment of any penalty herein provided shall not relieve a person, firm or corporation from the responsibility of correcting the conditions consisting of the violation.

**SECTION 3.** All other provisions of Chapter 35 of the City Code of San Antonio, Texas, shall remain in full force and effect unless expressly amended by this Ordinance.

**SECTION 4.** Should any Article, Section, Part, Paragraph, Sentence, Phrase, Clause, or Word of this Ordinance, or any appendix thereof, for any reason, be held illegal, inoperative, or invalid, or if any exception to or limitation upon any general provision herein contained be held to be unconstitutional or invalid or ineffective, the remainder shall, nevertheless, stand effective and valid as if it had been enacted and ordained without the portion held to be unconstitutional or invalid or ineffective.

**SECTION 5.** Notice of these changes to the Unified Development Code shall not require the publication in an official newspaper of general circulation in accordance with Chapter 35, Article IV, Division 1, Table 403-1.

**SECTION 6.** The publishers of the City Code of San Antonio are authorized to amend said Code to reflect the changes adopted herein, to correct typographical errors and to index, format and number paragraphs to conform to the existing code.

**SECTION 7.** The City Clerk for the City of San Antonio is hereby directed to publish notice of this Ordinance in a newspaper published in the City of San Antonio, Texas, as required by Article 2, Section 17 of the City Charter of San Antonio, Texas.

**SECTION 8.** This Ordinance shall be effective on December 21, 2008.

**PASSED AND APPROVED this 11<sup>th</sup> day of December 2008.**

**M A Y O R**

**ATTEST:**

**City Clerk**

**APPROVED AS TO FORM:**

**Office of the City Attorney**

---

**City Attorney**